

## Technical Data

Contact rating (max)	W / VA	3
Max. switching voltage	VDC	50
	VAC	50
Max. switching current	A	0.2
Max. limiting current at 125% p.i.	A	0.5
<i>Parameters above have to be strictly observed !!</i>		

Standard pull in range (p.i.)	AT	10-25
Release range	AT	5
Max. initial contact resistance at 125% p.i.	mΩ	150
Min. insulation resistance	Ω	10 <sup>9</sup>
Min. dielectric strength	VDC	100
	VAC	100
Max. switching frequency	Hz	100
Typical operating time at 125% p.i.	ms	2.5
Typical release time (without diode)	ms	0.02
Typical bounce time 150% p.i. 50Hz	ms	0.6
Capacitance (open contacts)	pF	0.8

## Environmental conditions

Operating temperature	°C	-40 to +130
Max. vibration (50-2000 Hz)	g	30
Max. shock during half sin 11ms	g	50

All data are for unmodified reed switches measured using standard test coil with 10 000 turns, wire diameter 0.06mm and coil resistance 1600 Ω.

## Dimensions (mm)

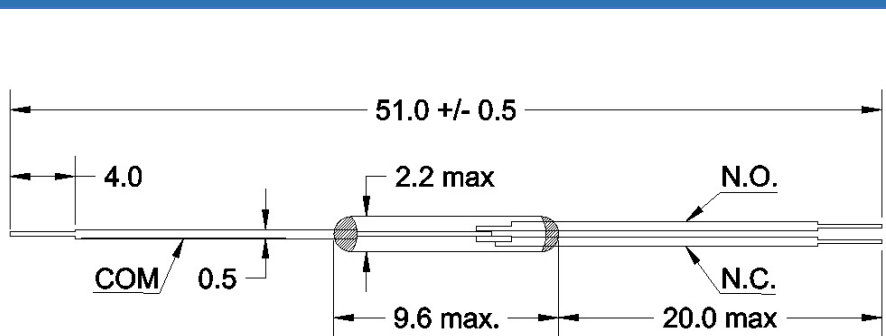

## Changeover Reed Switch JRCM / ORC-8

Form C Switch  
JanusReedContactMiniature

### Excellent reliability and life expectancy

- World smallest Form C RS with closed difference properties
- Original JanusReedContact
- Contact material Rh
- 3W, 0,2A changeover switch
- Filled with inert gas
- Gold-plated leads
- Actuation by permanent magnet or electromagnet
- Tight hysteresis possible
- AT range from 10 to 25 possible

#### Application:

- Measurement systems
- Proximity sensors
- Position detection
- Fluid level sensing, etc.

#### Handling and modification:

Reed switch must be protected while handling, cutting, bending, mounting, encapsulating, welding, soldering etc. During modification, care must be taken not to apply excessive mechanical force that could result in hermetic seal damage. Recommended distance from end of glass capsule for lead bending and cutting is no less than 1,2mm. We can offer crop and form customisation to your specification.

#### Ordering:

Packaging factor = 200pcs  
AT ranges and modification on your choice and based on your drawings.